



**PROTOTYPE**™  
RACING PARTS



# COMPANY

## About us

### We test what we do!

The performance, efficiency and reliability are our base work priorities. Though lightweight, the stiffness of PROTOTYPE products are tested through a computationally intensive process to the limit, proven by elite athletes who have won more than 50 national and international titles, including the World Champion.

PROTOTYPE is totally committed with after sales support, giving technical solutions to allow find practical and simplified options.

We know where we are and where we want to go.

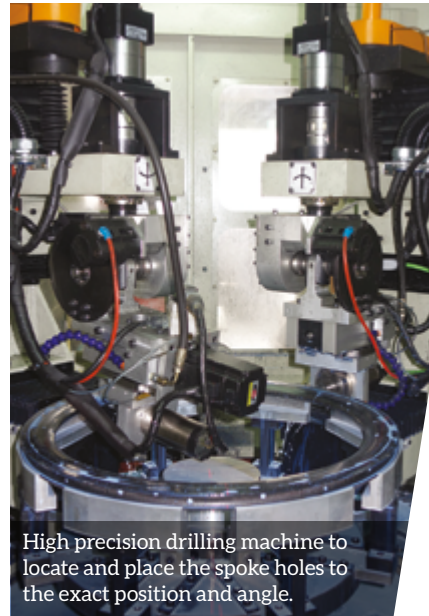

High precision drilling machine to locate and place the spoke holes to the exact position and angle.

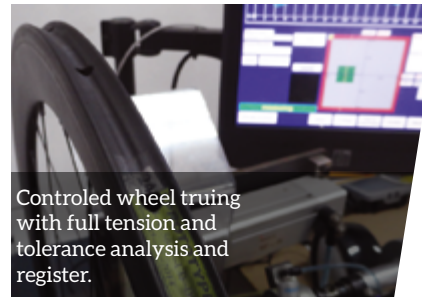

Controlled wheel truing with full tension and tolerance analysis and register.

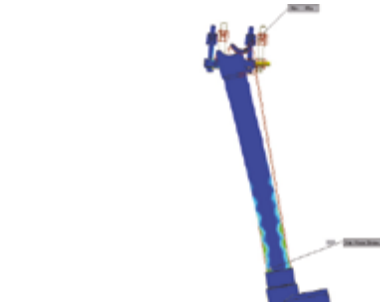

Finite element analysis (FEA) to calculate stresses and displacements of component displacements, strains under internal and external loads.

With the analysis results, we can catch design flaws and optimize features at the drawing stage.

CHAMPIONS ARE POWERED BY PROTOTYPE



“

*All wheels are built with unmatched attention to detail, we use high-precision tools, specially designed by us. We can offer a ride quality and durability that cannot be matched by a stock machine-built set.*

**Ivo Santos**

Prototype Technical Department

PROTOTYPE  
RACING PARTS



# WHEELS MTB



Amazing wheels, lightweight, stiff and very trustable. There's nothing similar in 29. The 33 width allows to low the tire pressure without taking risk.

**David Valero**

MMR Factory Racing Team





# CARBON

# WHEELS MTB WORLD CUP

## RIM Detail

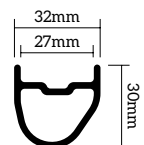

ASYMMETRIC  
HOOKLESS

## HUB Detail



Reference weight:  
**Clincher:** 29" EVO 4 SP Boost - 1410gr

MSRP: 1.850 €

Reference weight:  
**Clincher:** 29" EVO 4 Boost - 1430gr

MSRP: 1.750 €

**i** See more details  
on page 30.



**UCI**  
2019 WORLD  
CHAMPIONSHIP

**UEC**  
UNION EUROPEENNE  
DE CYCLISME  
2019 EUROPEAN  
CHAMPIONSHIP

## Decal Option



BLACK

# WHEELS MTB TEAM

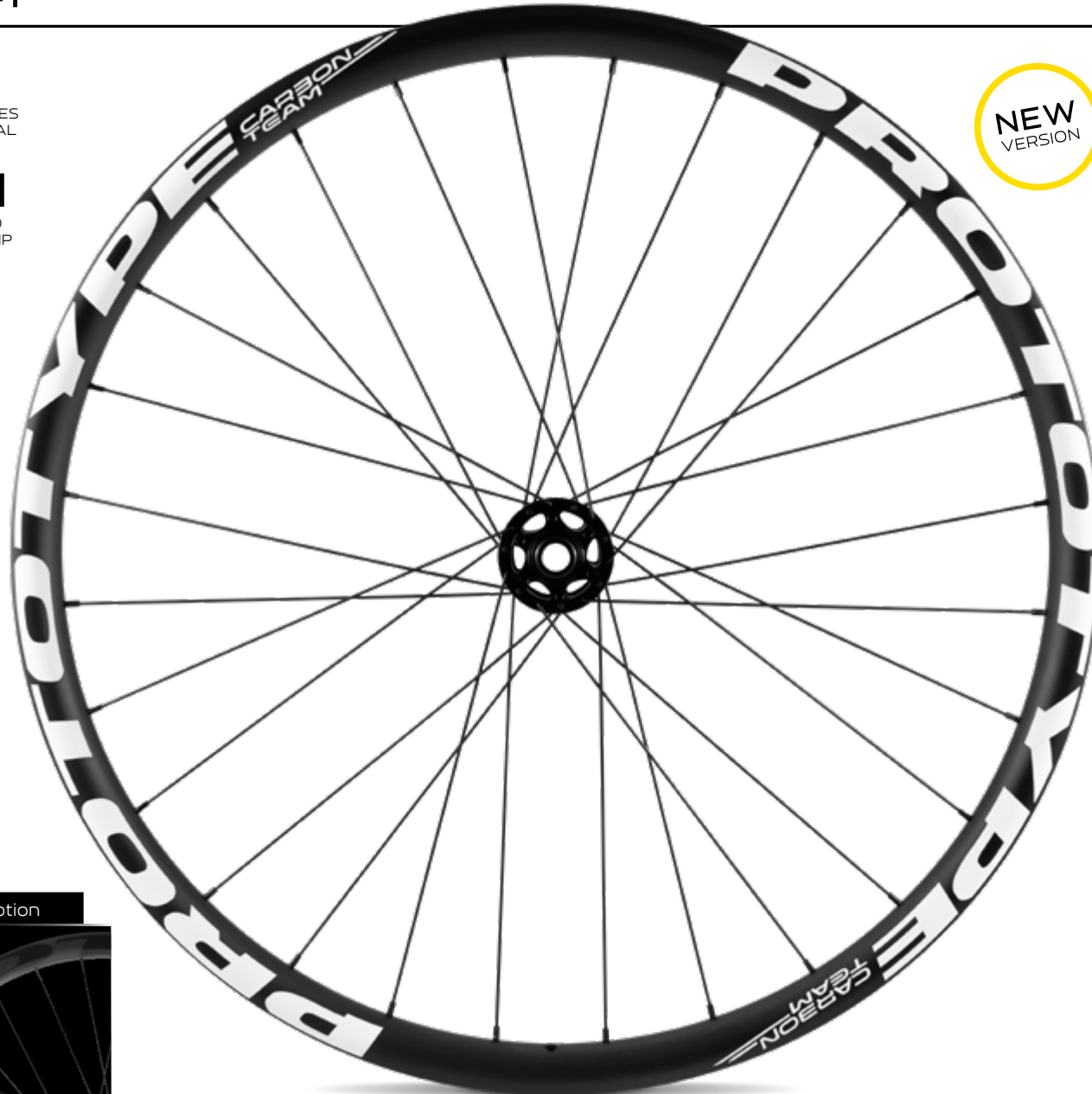

## C A R B O N

### RIM Detail

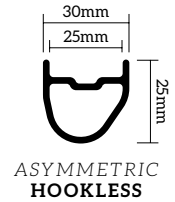

### HUB Detail



Reference weight:  
**Clincher:** 29" EVO 4 SP Boost - 1390gr

MSRP: 1.590 €

Reference weight:  
**Clincher:** 29" EVO 4 Boost - 1420gr

MSRP: 1.490 €

Decal Option



BLACK

**i** See more details on page 30.



# WHEELS MTB FLASH

## C A R B O N

RIM Detail

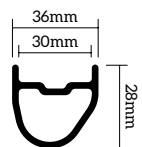

ASYMMETRIC  
HOOKLESS

HUB Detail



DECAL Detail



REAR HUB OPTION  
Extreme



Also available in 27,5".

Reference weight:  
Clincher: 29" Boost - 1680gr

MSRP: 1.150 €

**i** See more details  
on page 30.

WHEELS MTB  
**ZERO**

C A R B O N

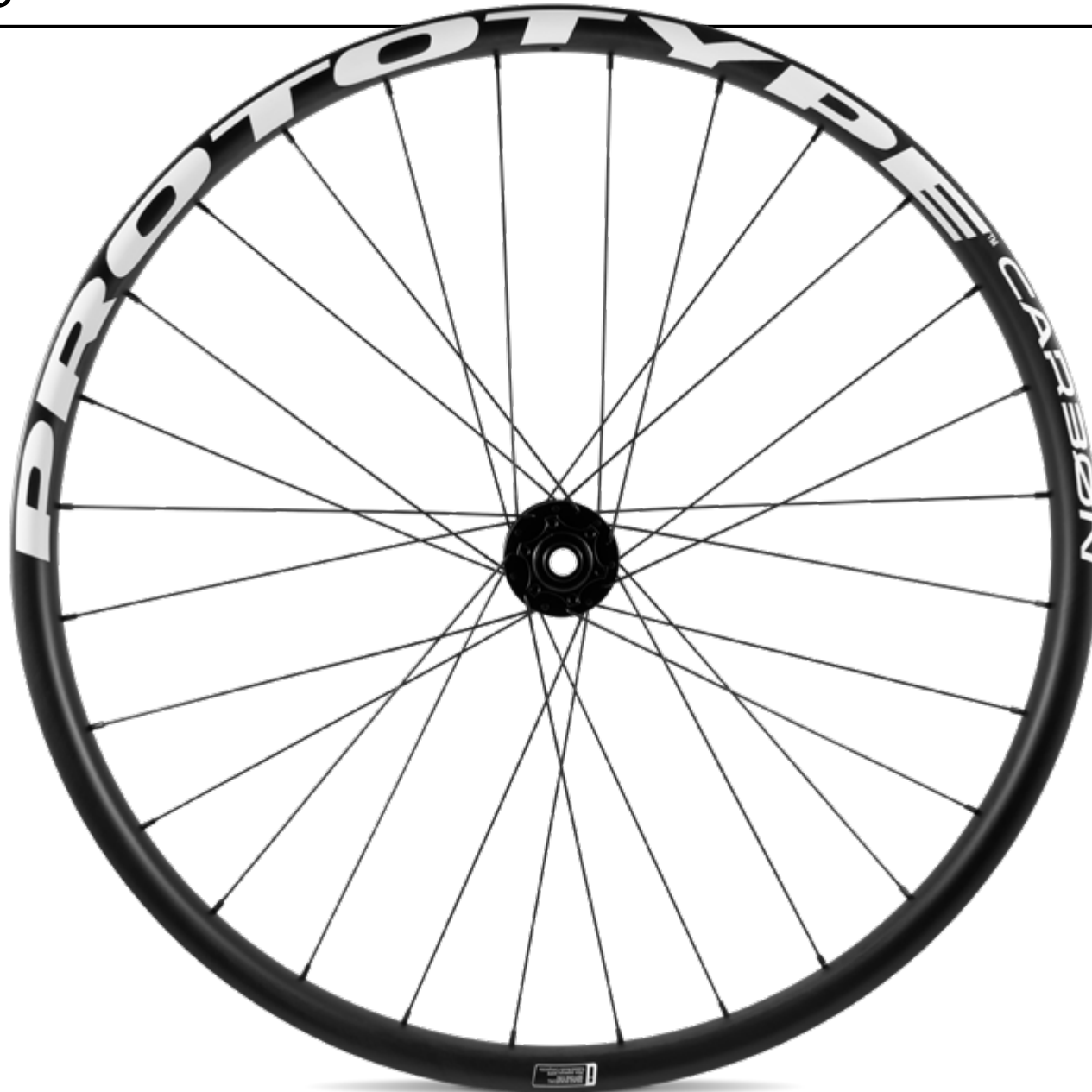

RIM Detail

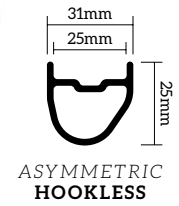

HUB Detail



Reference weight:  
**Clincher: 29" Boost - 1560gr**

MSRP: 990 €

**i** See more details  
on page 30.



# ALUMINIUM

RIM Detail

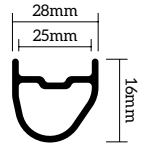

ASYMMETRIC  
HOOKLESS

HUB Detail



Reference weight:  
**Clincher:** 29" Boost - 1490gr

MSRP: 840 €

**f** See more details  
on page 30.

# WHEELS MTB ZENITH

**UCI**  
2016 WORLD  
CHAMPIONSHIP

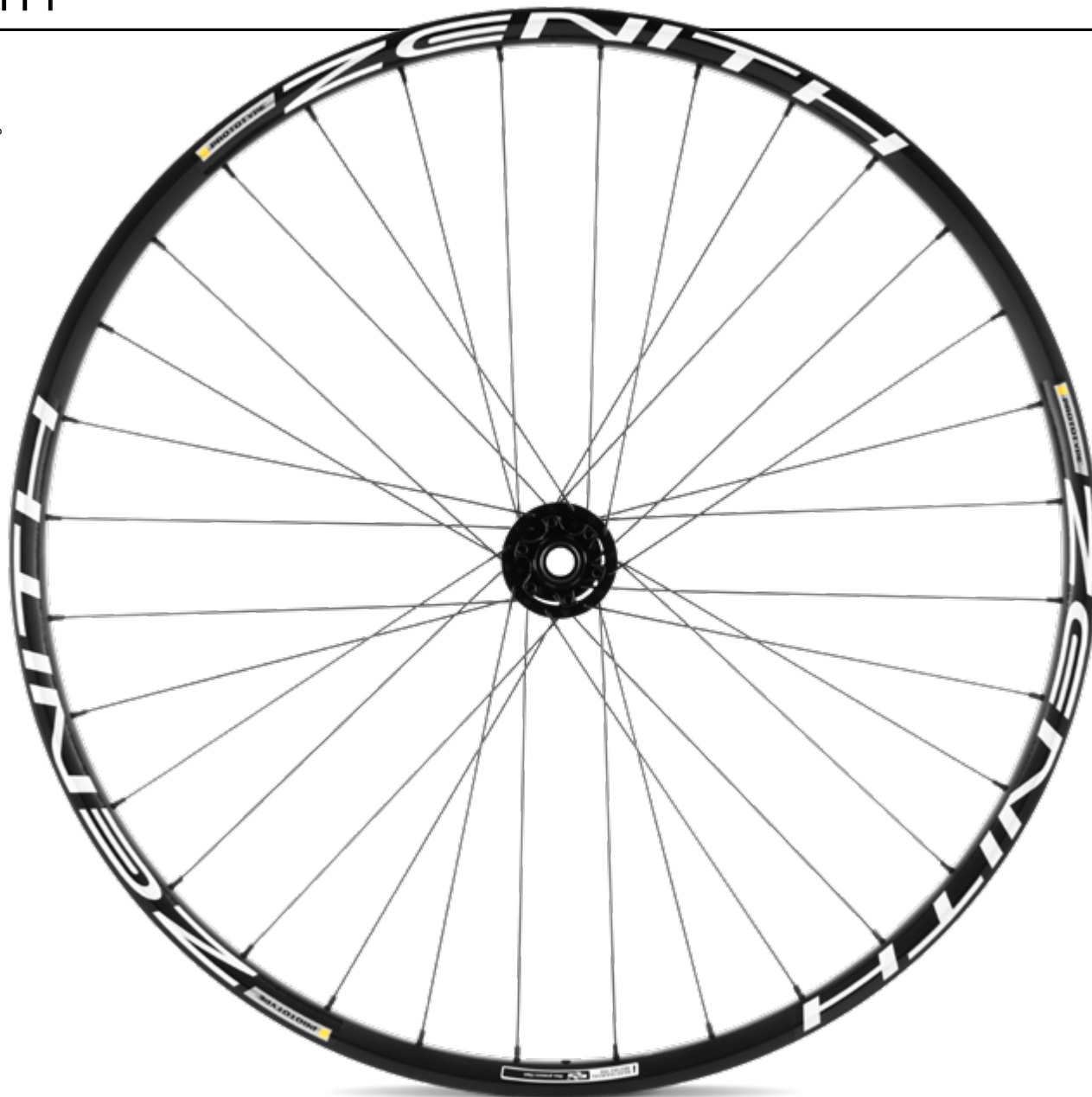

## ALUMINIUM

### RIM Detail

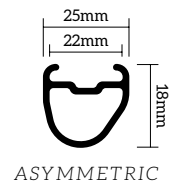

### HUB Detail



Reference weight:  
**Clincher: 29" Boost - 1460gr**

MSRP: 685 €

**i** See more details  
on page 30.



## ALUMINIUM

RIM Detail

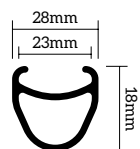

HUB Detail

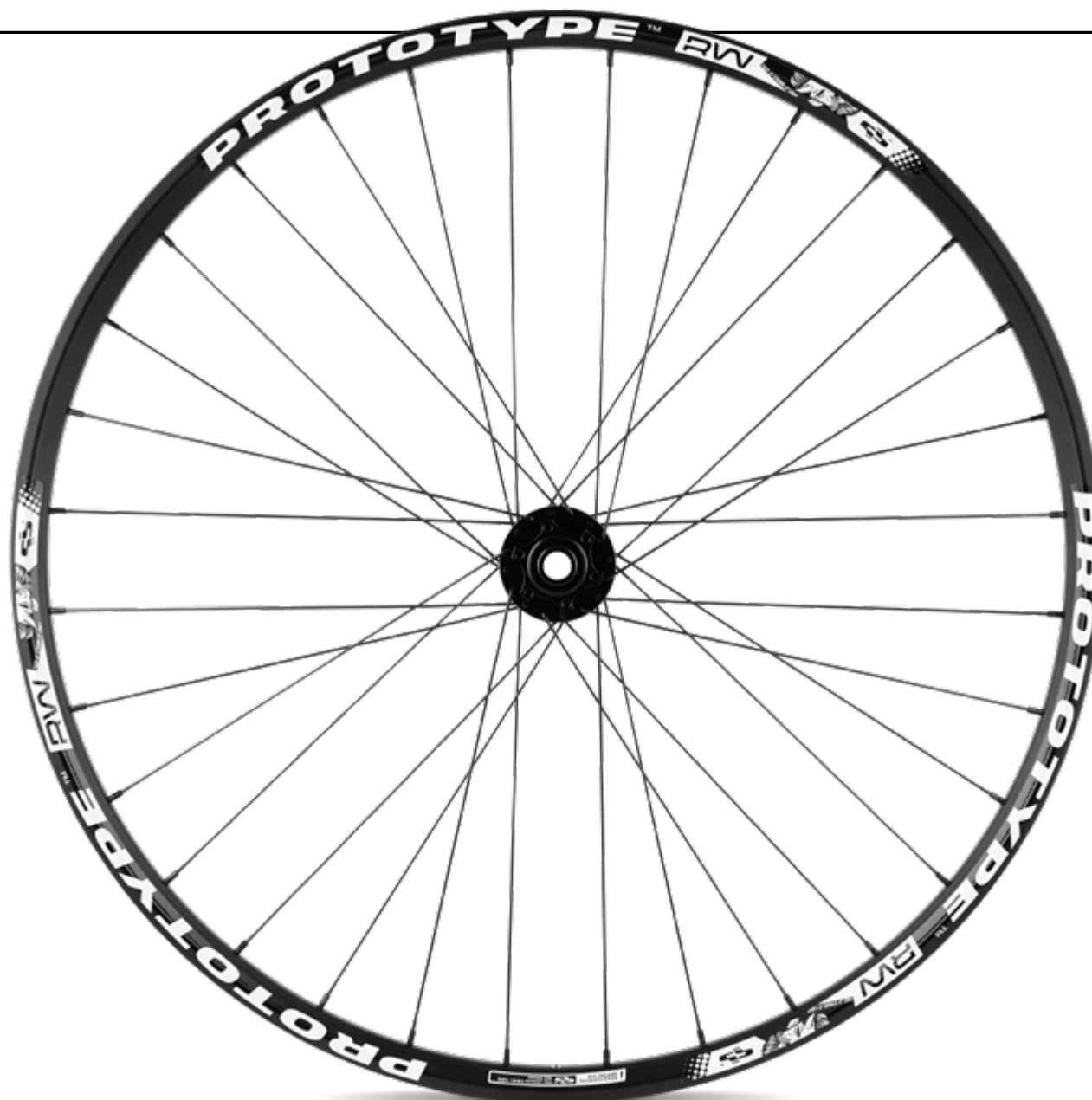

Also available in 27,5".

Reference weight:  
**Clincher:** 29" Boost - 1780gr

MSRP: 495 €

**i** See more details  
on page 30.

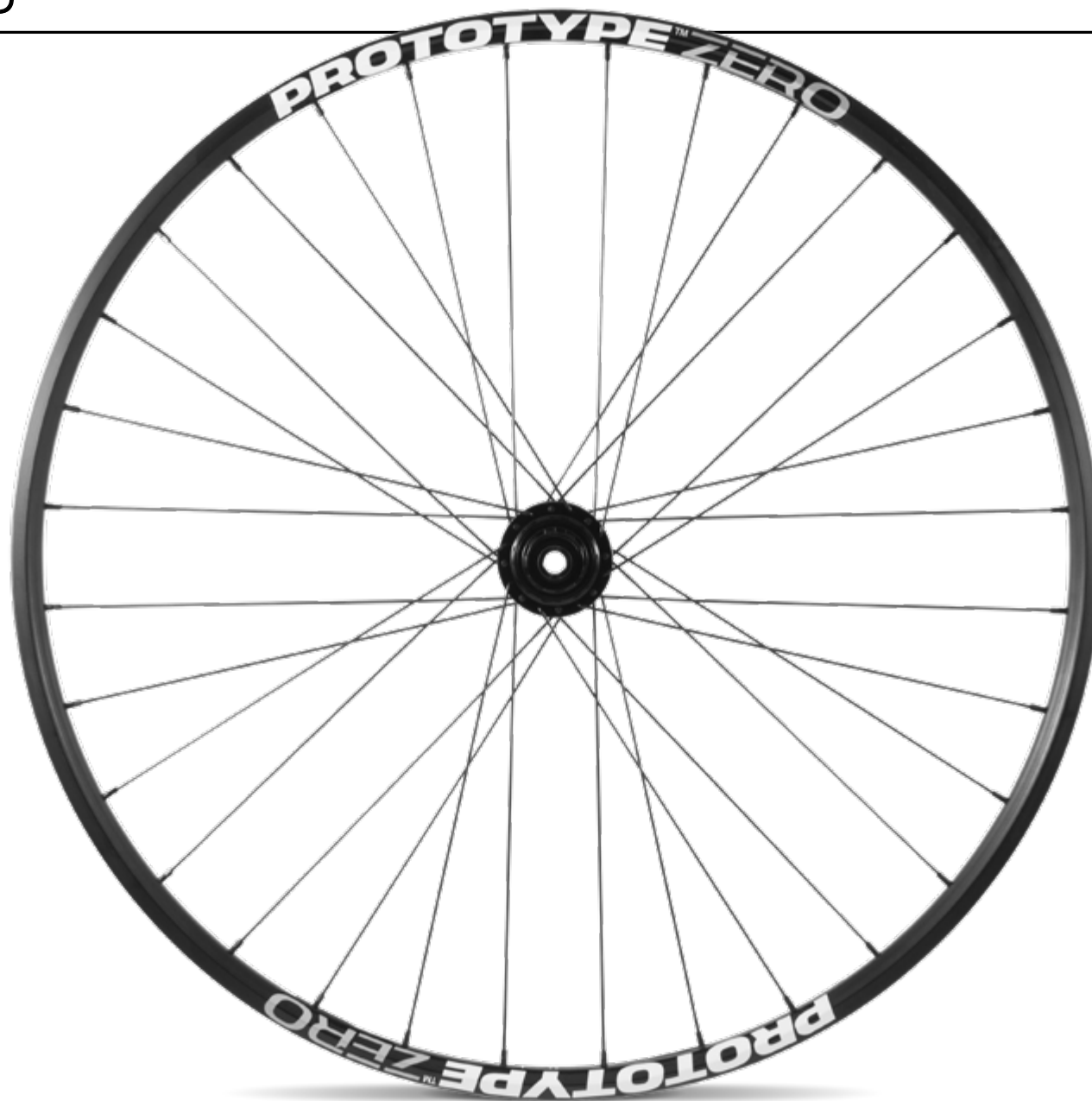

RIM Detail

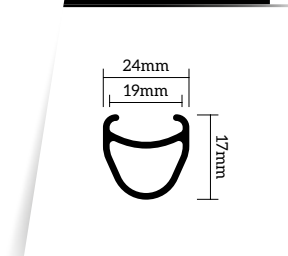

HUB Detail



Also available in 27,5".

Reference weight:  
Clincher: 29" Boost - 1770gr

MSRP: 395 €

**i** See more details  
on page 30.



# WHEELS ROAD



*The Prototype wheels surprised me by their lightness, stiffness and reliability during my trainings and races. I use and highly recommend them.*

**Daniel Silva**

RP Boavista Team



# WHEELS ROAD PROTOUR DISC 5

C A R B O N



### RIM Detail

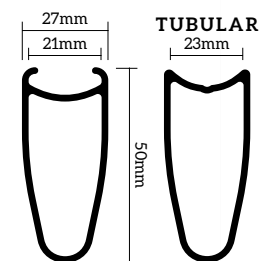

### HUB Detail



BRAKE OPTION  
6 holes (IS)



Reference weight:  
**Clincher:** 1560gr

MSRP: 1270 €

**i** See more details  
on page 31.



## C A R B O N

WHEELS ROAD  
PROTOUR DISC 3

## RIM Detail

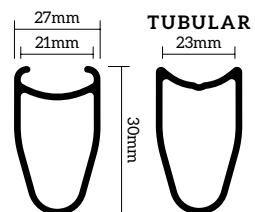

## HUB Detail



BRAKE OPTION  
6 holes (IS)



Reference weight:  
Clincher: 1425gr

MSRP: 1270 €

**i** See more details  
on page 31.



# WHEELS ROAD PROTOUR DISC AL

ALUMINIUM



RIM Detail

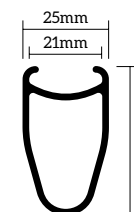

HUB Detail



**BRAKE OPTION**  
6 holes (IS)



Reference weight:  
**Clincher: 1560gr**

MSRP: 545 €

**i** See more details  
on page 31.

# CARBON

# WHEELS ROAD PROTOUR 5 SL

RIM Detail

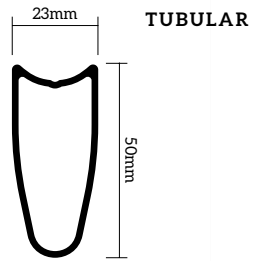

HUB Detail



Reference weight:  
Tubular: 1210gr

MSRP: 1490 €

**i** See more details  
on page 31.



# WHEELS ROAD PROTOUR 3 SL

C A R B O N



### RIM Detail

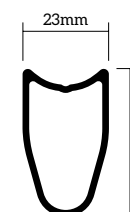

### HUB Detail



Reference weight:  
Tubular: 1150gr

MSRP: 1.490 €

**i** See more details  
on page 31.

C A R B O N

RIM Detail

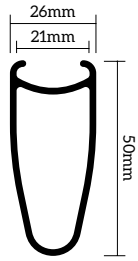

HUB Detail

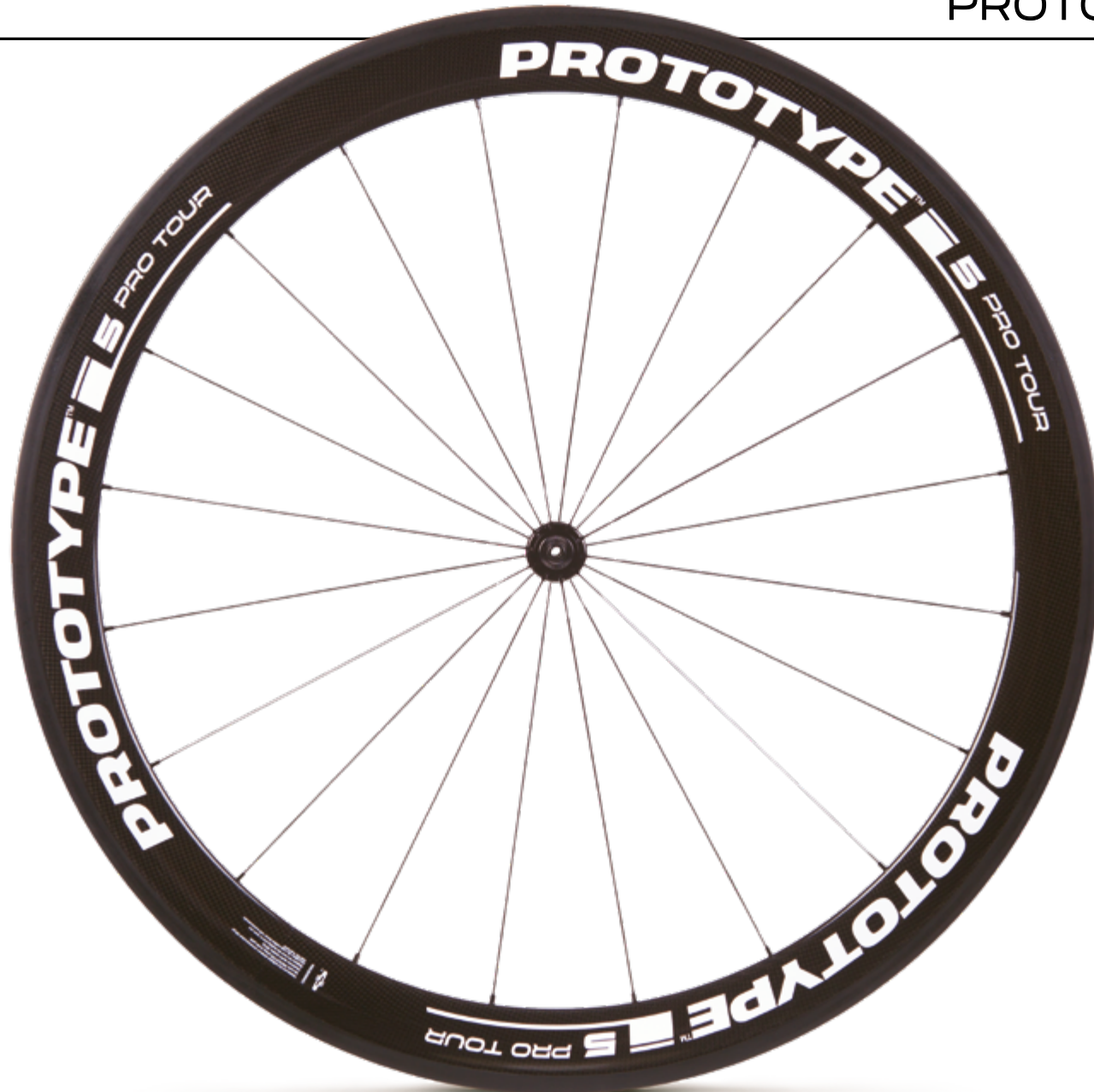

Reference weight:  
Clincher: 1550gr

MSRP: 1270 €

**i** See more details  
on page 31.

# WHEELS ROAD PROTOUR 3

C A R B O N



RIM Detail

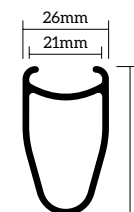

HUB Detail



Reference weight:  
**Clincher:** 1460gr

MSRP: 1270 €

**i** See more details  
on page 31.



CARBON & ALUMINIUM

WHEELS ROAD  
PROTOUR CA

RIM Detail

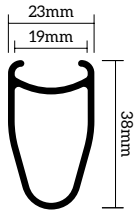

HUB Detail



Reference weight:  
Clincher: 1740gr

MSRP: 845 €

**i** See more details  
on page 31.

# WHEELS ROAD PRO TOUR AL

ALUMINIUM

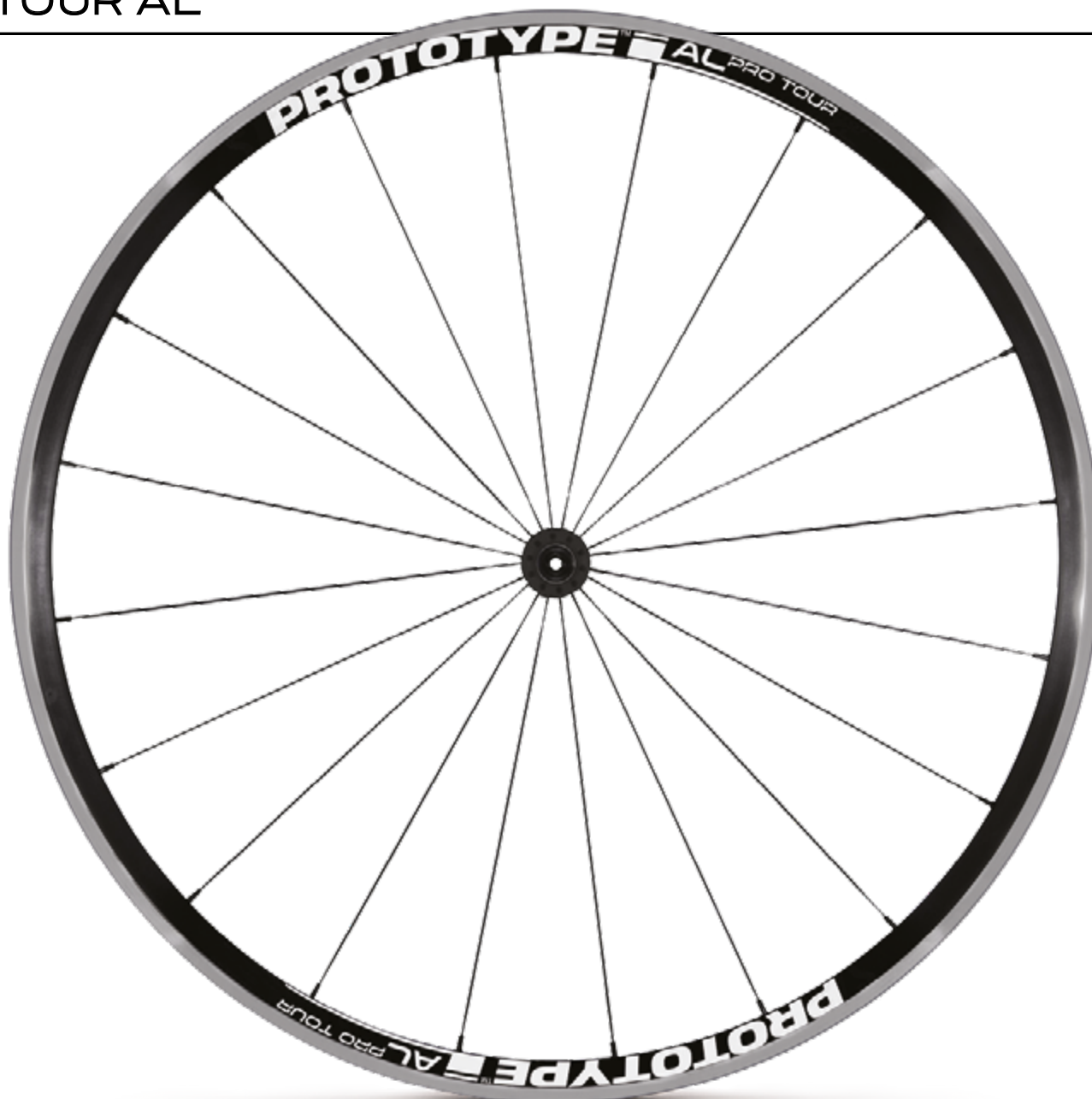

RIM Detail

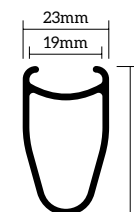

HUB Detail



Reference weight:  
**Clincher: 1590gr**

MSRP: 395 €

**i** See more details  
on page 31.

# WHEELS PROTOTYPE TRUE INSPIRATION

## SOME HEROES IN ACTION





# WHEELS TIME TRIAL TRIATHLON





C A R B O N

RIM Detail



Reference weight:  
Front: 690gr

MSRP: 580 €

Reference weight:  
Rear: 820gr

MSRP: 720 €

 See more details  
on page 32.

WHEELS TIME TRIAL TRIATHLON  
JOKER DISC

C A R B O N



Reference weight:  
Tubular: 1210gr  
MSRP: 1.450 €

**f** See more details  
on page 32.



# WHEELS CYCLOCROSS



Light, stiff and incredibly smooth. In such a tough discipline as cyclocross, a total confidence on your material is essential. And that confidence is what the new Prototype CX wheels can offer to me.

**Aida Nuño**

Cyclocross World Cup Athlete



# WHEELS CYCLOCROSS CX

C A R B O N

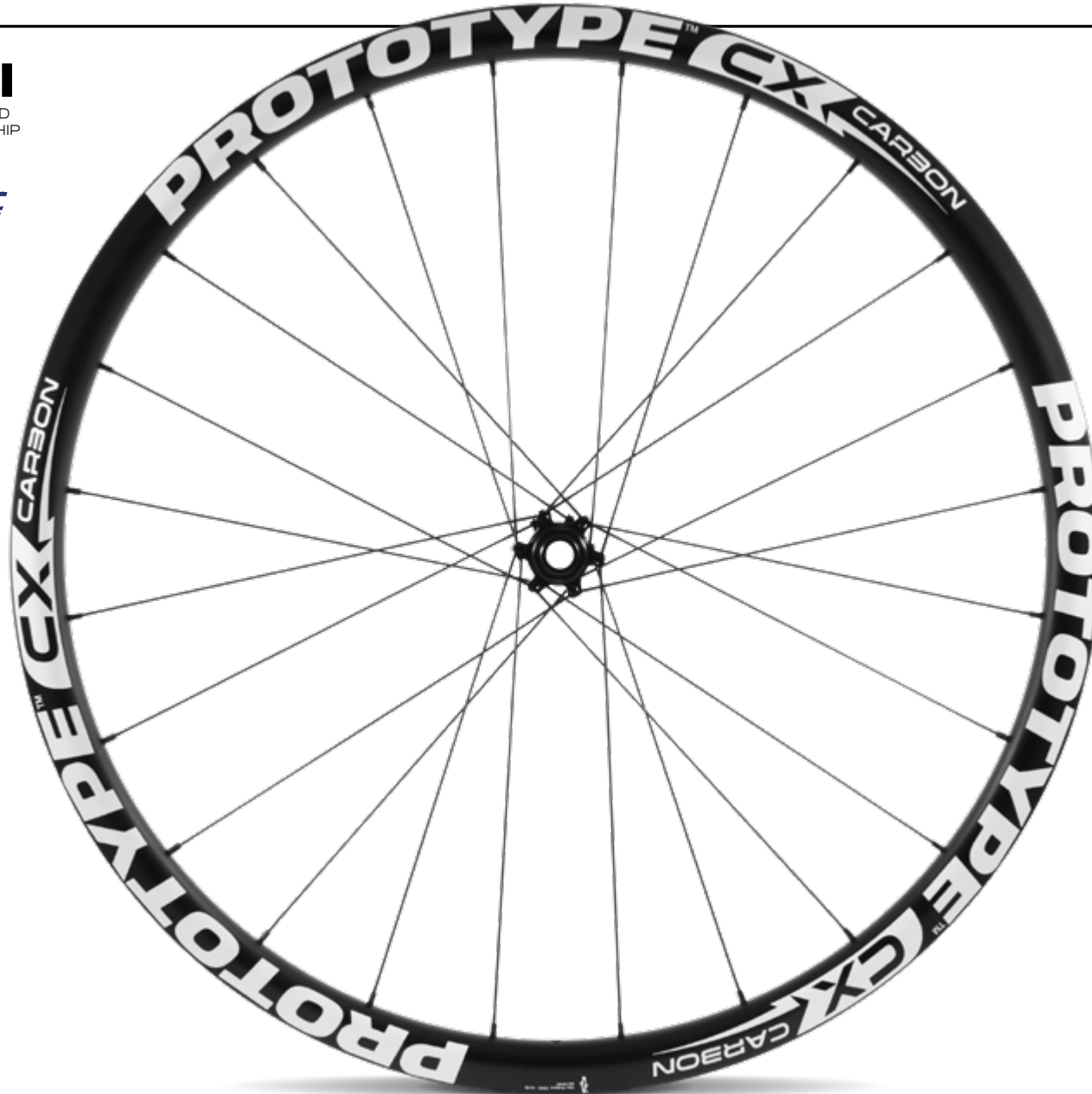

### RIM Detail

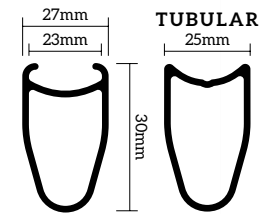

### HUB Detail



**BRAKE OPTION**  
6 holes (IS)



Reference weight:  
Clincher: 1430gr  
Tubular: 1190gr

MSRP: 1270 €

**i** See more details  
on page 32.

ALUMINIUM

RIM Detail

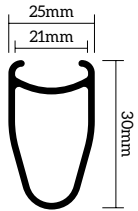

HUB Detail



BRAKE OPTION  
6 holes (IS)



Reference weight:  
Clincher: 1570gr

MSRP: 545 €

**i** See more details  
on page 32.

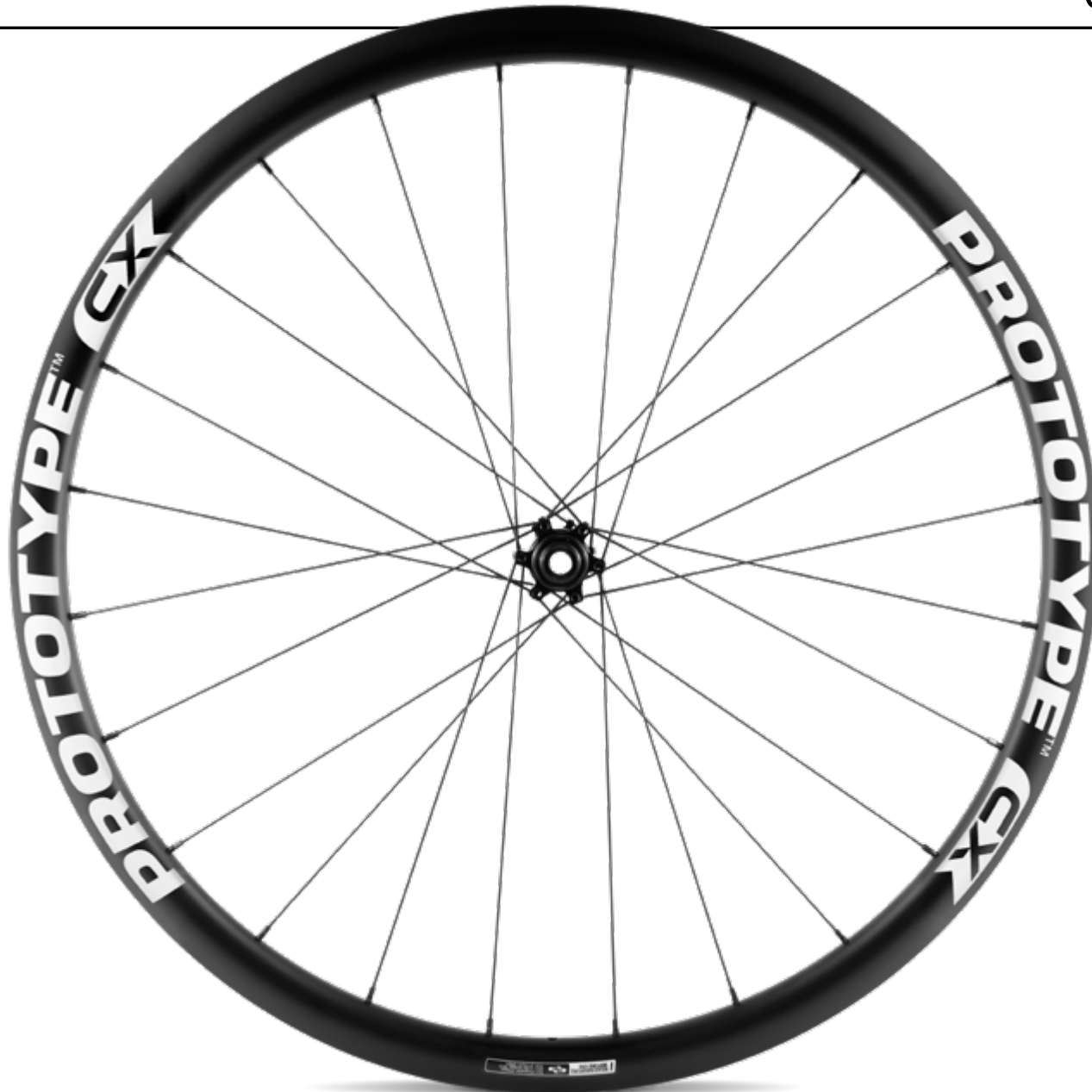



## TECHNICAL SPECIFICATIONS

# MTB WHEELS

|                              | World Cup SP              | World Cup                 | Carbon Team SP            | Carbon Team               | E-Flash Carbon 36                |
|------------------------------|---------------------------|---------------------------|---------------------------|---------------------------|----------------------------------|
| <b>Rim Material</b>          | Full Carbon               | Full Carbon               | Full Carbon               | Full Carbon               | Full Carbon                      |
| <b>Rim Width Inner/Outer</b> | 27/32                     | 27/32                     | 25/30                     | 25/30                     | 30 / 36                          |
| <b>Profile</b>               | 30                        | 30                        | 26                        | 26                        | 28                               |
| <b>Tire Size / Width</b>     | 29" / 2.0 to 2.5          | 29" / 2.0 to 2.5          | 29" / 1.5 to 2.1          | 29" / 2.0 to 2.5          | 29" / 2.1 to 2.5                 |
| <b>Tire Type</b>             | Tubeless ready            | Tubeless ready            | Tubeless ready            | Tubeless ready            | Clincher                         |
| <b>Spoke</b>                 | Aero SL 2.0 - SP          | Aero 2.0 - J bend         | Aero SL 2.0 - SP          | Aero 2.0 - J bend         | Round                            |
| <b>Nipple</b>                | Aluminium                 | Aluminium                 | Aluminium                 | Aluminium                 | Aluminium                        |
| <b>Hub Model*</b>            | EVO 4 SP                  | EVO 4                     | EVO 4 SP                  | EVO 4                     | FSL 3.0 Extreme                  |
| <b>Freewheel Body</b>        | SH 11 / XD / Micro Spline | SH 11 / XD / Micro Spline | SH 11 / XD / Micro Spline | SH 11 / XD / Micro Spline | e-SH / SH 11 / XD / Micro Spline |
| <b>Braking</b>               | Disc Brake IS             | Disc Brake IS             | Disc Brake IS             | Disc Brake IS             | IS                               |
| <b>ASTM **</b>               | 3                         | 3                         | 3                         | 3                         | 3                                |
| <b>Discipline</b>            | XCO / XCM                 | XCO / XCM                 | XCO / XCM                 | XCO / XCM                 | E-Bikes / AM                     |
| <b>Weight Limit</b>          | 100kg                     | 90kg                      | 100kg                     | 90kg                      | 110kg                            |
| <b>Weight (Boost)</b>        | 1410gr                    | 1430gr                    | 1390gr                    | 1420gr                    | 1680gr                           |

|                              | Carbon Zer0               | Zenith Team               | Zenith                    | RW                        | Zero                      |
|------------------------------|---------------------------|---------------------------|---------------------------|---------------------------|---------------------------|
| <b>Rim Material</b>          | Full Carbon               | Aluminium                 | Aluminium                 | Aluminium                 | Aluminium                 |
| <b>Rim Width Inner/Outer</b> | 25/31                     | 25/28                     | 22/25                     | 23/28                     | 22/25                     |
| <b>Profile</b>               | 25                        | 16                        | 18                        | 18                        | 17                        |
| <b>Tire Size / Width</b>     | 29" / 2.0 to 2.5          | 29" / 2.0 to 2.2          | 29" / 1.7 to 2.1          | 29" / 1.8 to 2.5          | 29" / 1.0 to 2.1          |
| <b>Tire Type</b>             | Tubeless ready            | Tubeless ready            | Tubeless ready            | Tubeless ready            | Tubeless ready            |
| <b>Spoke</b>                 | Round - J Bend            | Aero SL 2.0 - J Bend      | Round - J Bend            | Round - J Bend            | Round - J Bend            |
| <b>Nipple</b>                | Aluminium                 | Aluminium                 | Aluminium                 | Aluminium                 | Aluminium                 |
| <b>Hub Model*</b>            | FSL 3.0                   | EVO 4                     | EVO 3.1                   | FSL 3.0                   | FSL 3.0                   |
| <b>Freewheel Body</b>        | SH 11 / XD / Micro Spline | SH 11 / XD / Micro Spline | SH 11 / XD / Micro Spline | SH 11 / XD / Micro Spline | SH 11 / XD / Micro Spline |
| <b>Braking</b>               | Disc Brake IS             | Disc Brake IS             | Disc Brake IS             | Disc Brake IS             | Disc Brake IS             |
| <b>ASTM **</b>               | 3                         | 3                         | 3                         | 3                         | 3                         |
| <b>Discipline</b>            | XCO / XCM                 | XCO / XCM                 | XCO / XCM                 | XCO / XCM                 | XCO / XCM                 |
| <b>Weight Limit</b>          | 100kg                     | 85kg                      | 85kg                      | 110kg                     | 95kg                      |
| <b>Weight (Boost)</b>        | 1560gr                    | 1490gr                    | 1460gr                    | 1780gr                    | 1770gr                    |

Note: The weights indication is just a reference value.

## TECHNICAL SPECIFICATIONS ROAD DISC WHEELS

|                              | Pro Tour Disc 5           | Pro Tour Disc 3           | Pro Tour Disc AL          |
|------------------------------|---------------------------|---------------------------|---------------------------|
| <b>Rim Material</b>          | Full Carbon               | Full Carbon               | Aluminium                 |
| <b>Rim Width Inner/Outer</b> | 20 / 27                   | 20 / 27                   | 20 / 27                   |
| <b>Profile</b>               | 50                        | 30                        | 30                        |
| <b>Tire Size / Width</b>     | 700x19/27c Tubeless Ready | 700x19/27c Tubeless Ready | 700x19/27c Tubeless Ready |
| <b>Tire Type</b>             | Clincher                  | Clincher                  | Clincher                  |
| <b>Spoke</b>                 | Aero                      | Aero                      | Round                     |
| <b>Nipple</b>                | Aluminium                 | Aluminium                 | Aluminium                 |
| <b>Hub Model*</b>            | SP Disc                   | SP Disc                   | SP Disc                   |
| <b>Freewheel Body</b>        | SH / XDR / Campagnolo     | SH / XDR / Campagnolo     | SH / XDR / Campagnolo     |
| <b>Braking</b>               | IS or Center-Lock         | IS or Center-Lock         | IS or Center-Lock         |
| <b>ASTM **</b>               | 1                         | 1                         | 1                         |
| <b>Discipline</b>            | Road                      | Road                      | Road                      |
| <b>Weight Limit***</b>       | 120kg                     | 110kg                     | 100kg                     |
| <b>Weight</b>                | 1560gr                    | 1425gr                    | 1560gr                    |

## ROAD WHEELS

|                              | Pro Tour 5 SL         | Pro Tour 3 SL         | Pro Tour 5                | Pro Tour 3                | Pro Tour CA           | Pro Tour AL               |
|------------------------------|-----------------------|-----------------------|---------------------------|---------------------------|-----------------------|---------------------------|
| <b>Rim Material</b>          | Full Carbon           | Full Carbon           | Full Carbon               | Full Carbon               | Aluminium-Carbon      | Aluminium                 |
| <b>Rim Width Inner/Outer</b> | 23                    | 23                    | 25                        | 25                        | 23                    | 23                        |
| <b>Profile</b>               | 50                    | 38                    | 50                        | 38                        | 38                    | 26                        |
| <b>Tire Size / Width</b>     | 700x19/25c            | 700x19/25c            | 700x19/25c Tubeless Ready | 700x19/25c Tubeless Ready | 700x21/25c            | 700x21/25c Tubeless Ready |
| <b>Tire Type</b>             | Tubular               | Tubular               | Clincher                  | Clincher                  | Clincher              | Clincher                  |
| <b>Spoke</b>                 | Aero SL 2.0 SP        | Aero SL 2.0 SP        | Aero 2.0 SP               | Aero 2.0 SP               | Round - J Bend        | Round - J Bend            |
| <b>Nipple</b>                | Aluminium             | Aluminium             | Aluminium                 | Aluminium                 | Aluminium             | Aluminium                 |
| <b>Hub Model*</b>            | SP 2                  | SP 2                  | SP 2                      | SP 2                      | SPEED 16              | SPEED 16                  |
| <b>Freewheel Body</b>        | SH / XDR / Campagnolo | SH / XDR / Campagnolo | SH / XDR / Campagnolo     | SH / XDR / Campagnolo     | SH / XDR / Campagnolo | SH / XDR / Campagnolo     |
| <b>Braking</b>               | Caliper               | Caliper               | Caliper                   | Caliper                   | Caliper               | Caliper                   |
| <b>ASTM **</b>               | 1                     | 1                     | 1                         | 1                         | 1                     | 1                         |
| <b>Discipline</b>            | Road                  | Road                  | Road                      | Road                      | Road                  | Road                      |
| <b>Weight Limit</b>          | 85kg                  | 80kg                  | 85kg                      | 100kg                     | 110kg                 | 85kg                      |
| <b>Weight (Boost)</b>        | 1210gr                | 1150gr                | 1550gr                    | 1460gr                    | 1740gr                | 1590gr                    |

**Note:** The weights (limit and boost) indication is just a reference value.

\* - Consult hub compatibility in our web site

\*\* - Consult ASTM in our web site

## TECHNICAL SPECIFICATIONS

# TIME TRIAL TRIATHLON WHEELS

|                       | Joker 8 Front  | Joker 8 Rear          | Joker Disc            |
|-----------------------|----------------|-----------------------|-----------------------|
| Rim Material          | Full Carbon    | Full Carbon           | Full Carbon           |
| Rim Width Inner/Outer | 23             | 23                    | 23                    |
| Profile               | 88             | 88                    | -                     |
| Tire Size / Width     | 700x19/25c     | 700x19/25c            | 700x19/25c            |
| Tire Type             | Tubular        | Tubular               | Tubular               |
| Spoke                 | Aero SL 2.0 SP | Aero SL 2.0 SP        | Full Carbon           |
| Nipple                | Aluminium      | Aluminium             | Aluminium             |
| Hub Model*            | SP 2           | SP 2                  | SP 2                  |
| Freewheel Body        | -              | SH / XDR / Campagnolo | SH / XDR / Campagnolo |
| Braking               | Caliper        | Caliper               | Caliper               |
| ASTM**                | 1              | 1                     | 1                     |
| Discipline            | Road           | Road                  | Road                  |
| Weight Limit          | 100kg          | 100kg                 | 100kg                 |
| Weight                | 690gr          | 820gr                 | 1210gr                |

## CYCLOCROSS WHEELS

|                       | CX Tubular            | CX Clincher           | CX AL                     |
|-----------------------|-----------------------|-----------------------|---------------------------|
| Rim Material          | Full Carbon           | Full Carbon           | Aluminium                 |
| Rim Width Inner/Outer | 25                    | 27                    | 20 / 27                   |
| Profile               | 30                    | 30                    | 30                        |
| Tire Size / Width     | 700x23/32c            | 700x23/32c            | 700x19/27c Tubeless Ready |
| Tire Type             | Tubular               | Clincher              | Clincher                  |
| Spoke                 | Round SL              | Round SL              | Round                     |
| Nipple                | Aluminium             | Aluminium             | Aluminium                 |
| Hub Model*            | SP Disc               | SP Disc               | SP Disc                   |
| Freewheel Body        | SH / XDR / Campagnolo | SH / XDR / Campagnolo | SH / XDR / Campagnolo     |
| Braking               | IS or Center-Lock     | IS or Center-Lock     | IS or Center-Lock         |
| ASTM**                | 2                     | 2                     | 2                         |
| Discipline            | CX / Gravel           | CX / Gravel           | CX / Gravel               |
| Weight Limit          | 85kg                  | 85kg                  | 100kg                     |
| Weight                | 1190gr                | 1430gr                | 1570gr                    |

**Note:** The weights indication is just a reference value.

\* - Consult hub compatibility in our web site

\*\* - Consult ASTM in our web site

\*\*\* - Weight Limit = rider weight + complet bike



# HUBS MTB ROAD



I find in Prototype a constant concern with optimization and reliability. The EVO 4 SP managed to exceed all my expectations!!!

**Angel Gomez (Litu)**

Mechanical and team manager MMR Factory Racing Team



HUBS  
MTB

Flange spacing has been designed for minimal difference in spoke tension between right and left side spokes Freewheel with four “Big Pawls” to evenly distribute the loads on a large surface.

FRONT

EVO 4 SP

**Color:** Black  
**Rotor Compatibility:** IS - 6Bolt  
**Bearings:** Prototype PRO 2  
*Optional: Ceramic Bearings*  
**Holes:** 28 | 32  
**O.L.D.:** 15x110mm  
*Optional Rock Shox cap*  
**Weight:** 109gr



MSRP: 215 €

FSL 3.0

**Color:** Black  
**Rotor Compatibility:** IS - 6Bolt  
**Bearings:** Prototype PRO 2  
**Holes:** 28 | 32  
**O.L.D.:** 9x100mm / 15x100mm | 15x110mm  
**Weight:** 126gr | 152gr



MSRP: 80 €

LEFTY

**Color:** Black  
**Rotor Compatibility:** IS - 6Bolt  
**Bearings:** Prototype PRO 2  
*Optional: Ceramic Bearings*  
**Holes:** 28 | 32  
**Weight:** 114gr (alloy bolt)



MSRP: 145 €

REAR

EVO 4 SP

**Color:** Black  
**Rotor Compatibility:** IS - 6Bolt  
**Bearings:** Prototype PRO 2  
*Optional: Ceramic Bearings*  
**Holes:** 28 | 32  
**O.L.D.:** 12x148mm  
**Cassete body:** Shimano 10|11s  
*Optional: Sram XD | Micro Spline*  
**Weight:** 239gr (XD)



MSRP: 365 €

FSL 3.0

**Color:** Black  
**Rotor Compatibility:** IS - 6Bolt  
**Bearings:** Prototype PRO 2  
**Holes:** 28 | 32  
**O.L.D.:** 10x135mm / 12x142mm | 12x148mm  
**Cassete body:** Shimano 10|11s  
*Optional: Sram XD | Micro Spline | E-Bike Shimano*  
**Weight:** 260gr | 284gr



MSRP: 180 €

LEFTY SUPERMAX

**Color:** Black  
**Rotor Compatibility:** IS - 6Bolt  
**Bearings:** Prototype PRO 2  
*Optional: Ceramic Bearings*  
**Holes:** 28 | 32  
**Weight:** 124gr (alloy bolt)



MSRP: 145 €

FRONT

SP 2

**Color:** Black  
**Bearings:** Prototype PRO 2  
*Optional: Ceramic Bearings*  
**Holes:** 20  
**O.L.D.:** 9x100mm  
**Weight:** 101gr



MSRP: 135 €

SP Disc

**Color:** Black  
**Rotor Compatibility:** IS - 6Bolt  
**Bearings:** Prototype PRO 2  
*Optional: Ceramic Bearings*  
**Holes:** 24  
**O.L.D.:** 9x100mm / 12x100mm / 15x100mm  
**Weight:** 110gr



MSRP: 145 €

Speed 16

**Color:** Black  
**Bearings:** Prototype PRO  
**Holes:** 20  
**O.L.D.:** 9x100mm  
**Weight:** 82gr



MSRP: 80 €

REAR

SP 2

**Color:** Black  
**Rotor Compatibility:** IS - 6Bolt  
**Bearings:** Prototype PRO 2  
*Optional: Ceramic Bearings*  
**Holes:** 24  
**O.L.D.:** 10x135mm  
**Cassete body:** Shimano 10|11s  
*Optional: Campagnolo | XDR*  
**Weight:** 214gr



MSRP: 270 €

SP Disc

**Color:** Black  
**Rotor Compatibility:** IS - 6Bolt  
**Bearings:** Prototype PRO 2  
*Optional: Ceramic Bearings*  
**Holes:** 24  
**O.L.D.:** 10x135mm / 12x135mm / 12x142mm  
**Cassete body:** Shimano 10|11s  
*Optional: Campagnolo | XDR*  
**Weight:** 220gr



MSRP: 285 €

IS version also available



BRAKE OPTION  
6 holes (IS)

Speed 16

**Color:** Black  
**Bearings:** Prototype PRO  
*Optional: Ceramic Bearings*  
**Holes:** 24  
**O.L.D.:** 10x130mm  
**Cassete body:** Shimano 10|11s  
*Optional: Campagnolo | XDR*  
**Weight:** 200gr



MSRP: 180 €



# HUBS ACCESSORIES

## Spare parts

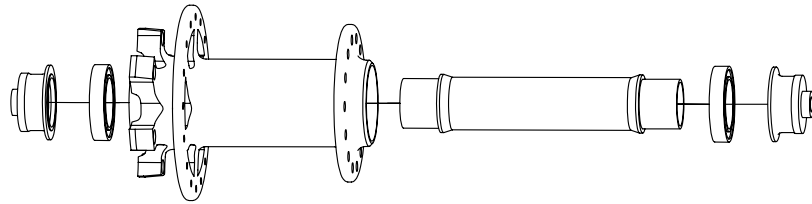

Front CAP Set  
9x100mm | 15x100mm | 15x110mm | RS1



PRO 2 Bearings  
Optional: Ceramic Bearings



Kit converts Evo 3/3.1 to RS1



Technical Support  
available at  
[www.prototype.pt/support/](http://www.prototype.pt/support/)

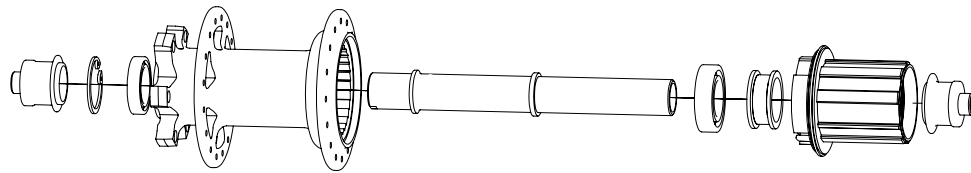

Rear CAP Set  
10x135mm | 12x142mm | 12x148mm



Shimano 10/11S



SRAM XD



Shimano Micro Spline

# WHEELS ACCESSORIES

## Road Brake Pads

These brake pads have been tested and approved for use with Prototype wheels.



### AL PRO

|                  |  |   |
|------------------|--|---|
| Brake Power Dry: |  | 9 |
| Brake Power Wet: |  | 6 |
| Longevity:       |  | 8 |
| Modulation:      |  | 7 |
| Temperature:     |  | 6 |
| Rim friendly:    |  | 9 |

Alloy Rim

MSRP: 10 €



### CARBON PRO 2

|                  |  |   |
|------------------|--|---|
| Brake Power Dry: |  | 9 |
| Brake Power Wet: |  | 8 |
| Longevity:       |  | 6 |
| Modulation:      |  | 7 |
| Temperature:     |  | 7 |
| Rim friendly:    |  | 9 |

Carbon Rim

MSRP: 19 €



### CARBON PRO 3

|                  |  |   |
|------------------|--|---|
| Brake Power Dry: |  | 9 |
| Brake Power Wet: |  | 8 |
| Longevity:       |  | 6 |
| Modulation:      |  | 7 |
| Temperature:     |  | 7 |
| Rim friendly:    |  | 9 |

Carbon Rim

MSRP: 19 €



Weight: MTB - 71gr  
Weight: Road - 69gr

MSRP: 32 €

## Valve Exten.

Material: Aluminum  
Weight: 1.8gr each  
Extend: 32mm  
Color: Black Anodized  
Item: Include 2 pcs



Only 1.8grams per wheel.

MSRP: 6 €

## TR Valves

Material: Aluminum with steel nut  
Weight: 4.2gr  
Height: 44mm  
Rubber Shape: Conic Round  
Color: Black or Red anodized



Removable Core

50% Lighter

Available colors



MSRP: 8.50 €

Material: Brass  
Weight: 8.4gr  
Height: 40mm  
Rubber Shape: Conic Round  
Color: Silver



Removable Core

MSRP: 6 €

## TR Rim Tape

Width: 23 / 25 / 27 / 29 mm  
Length: 5mts



MSRP: 7.50 €

## Sealant

Capacities: 150ml/500ml/5Lts



MSRP 150ml: 8.80 €

MSRP 500ml: 17 €

COMPONENTS  
PHYSIS CARBON



Carbon is in the sun,  
stars, comets and, soon,  
in your bike too.

Handlebar



*The ability to absorb vibrations is critical to reduce fatigue while stiffness is essential for the perfect control of a bike. Though very light, Physis handlebar is rigid and strengthened in grip areas.*

Length: 660mm/710 mm | 730mm (Team)  
Material: Aluminum Light Force  
Weight: 270gr | 210gr (Team)

MSRP: 53 € | 84 € (Team)

Stem



*Being the stem a key element for the perfect fit for riders' position, Physis stem distinguishes itself by its design, construction materials and vibration absorption capacity.*

Length: 6° and 17° > 80 mm ~ 130mm  
Material: Aluminum Light Force  
Bolts: Titanium  
Weight: 6° - 98gr (90mm) / 17° - 100gr (90mm)

MSRP: 68 €

Seat Clamp



Dimensions: 31.8 / 34.9 / 36.0 / 38.2  
Material: Aluminum Light Force  
Weight: 5.9gr (38.2)

Available colors



MSRP: 20 €

Bar Ends



Length: 75mm  
Material: Aluminum Light Force  
Weight: 46gr

Available colors



MSRP: 29.50 €

Seat Post



Length: 410 mm: 100-310mm  
Material: Aluminum Light Force  
Weight: 27.2 x 410 mm > 205 gr  
31.6 x 410 mm > 167 gr  
30.9 x 410 mm > 185 gr

Available colors



MSRP: 95 €



## COMPONENTS

## BOTTOM BRACKET

Our bottom brackets feature high quality sealed cartridge bearings

## BSA



**Frame Type:** BB BSA 1.37x24  
**Crankset:** Shimano, FSA, Rotor  
**CrankSet Axle:** 24mm  
**Bearings:** 6805 2RS  
**Weight:** 85gr

MSRP: 39 €

## BSA-GPX



**Frame Type:** BB BSA 1.37x24  
**Crankset:** SRAM GXP Type  
**CrankSet Axle:** 22-24mm  
**Bearings:** 6805 2RS  
**Weight:** 120gr

MSRP: 39 €

## BSA 30mm



**Frame Type:** BB BSA 1.37x24  
**CrankSet Axle:** 30mm  
**Bearings:** 6806 2RS  
**Weight:** 85gr

MSRP: 58 €

## PRESSFIT 41



**Frame Type:** BB 86,5/89.5/92  
**Frame BB ø:** 41mm  
**CrankSet:** Shimano, FSA  
**CrankSet Axle ø:** 24mm  
**Material:** Aluminum CNC  
**Bearings:** 6805 2RS  
**Weight:** 89gr

MSRP: 39.50 €



**Frame Type:** BB 86,5/89.5/92  
**Frame BB ø:** 41mm  
**CrankSet:** SRAM GXP  
**CrankSet Axle ø:** 20-24mm  
**Material:** Aluminum CNC  
**Bearings:** 6805 2RS  
**Weight:** 96gr

MSRP: 39.50 €

## PRESSFIT 30



**Frame Type:** BB PF30  
**Frame BB ø:** 46mm  
**CrankSet Axle ø:** 30mm  
**Bearings:** 6806 2RS  
**Material:** Aluminum CNC  
**Weight:** 112gr

MSRP: 39.50 €

**Lightweight, CNC machined, sealed bearing BB. CNC Alloy cups to press into 46mm internal BB shells. Our PF30 bottom bracket is a significant upgrade to any OEM PF30 bottom bracket. Two machined aluminum cups offer increased durability and bearing life, while keeping a simple press together method for installation and maintenance. This means no more creaking, smoother operation, longer bearing life.**

## PF 41-30mm



**Frame Type:** BB 86,5/89.5/92  
**Frame BB ø:** 41mm  
**CrankSet Axle ø:** 30mm  
**Bearings:** CNC modified  
**Weight:** 73gr

MSRP: 67 €

## ADAPTORS



**BB30 to 24mm Shimano**  
 Adapter fits a BB30 of PF30 bearings and reduces the diameter to work with Shimano Hollotech II crank sets.

**Weight:** 56gr

**BB30 to 24mm SRAM GXP**

Adapter fits a BB30 of PF30 bearings and reduces the diameter to work with SRAM cranks.

**Weight:** 70gr

MSRP: 17.50 €

Headset

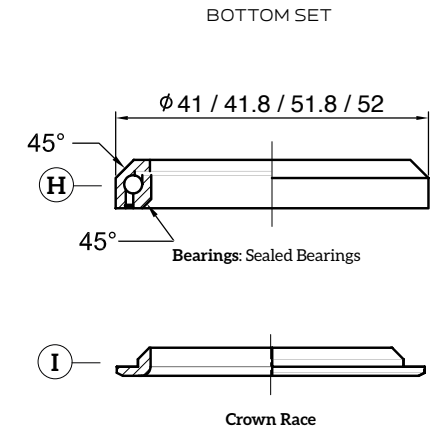
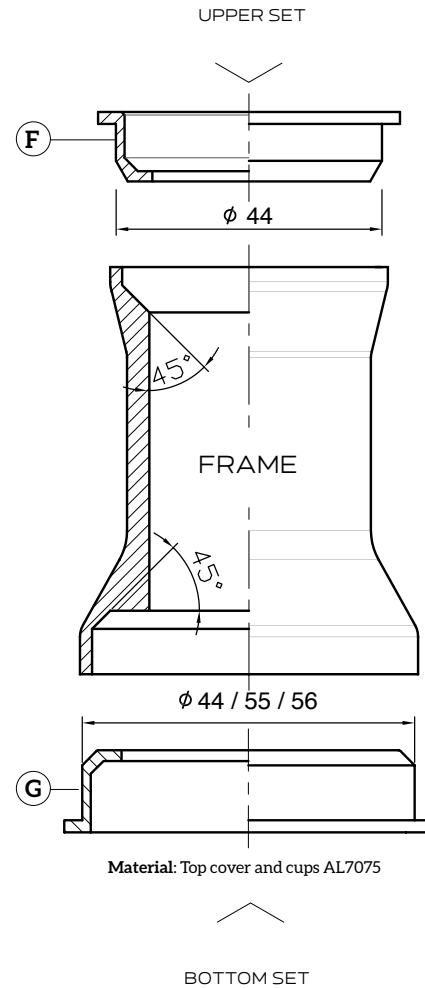
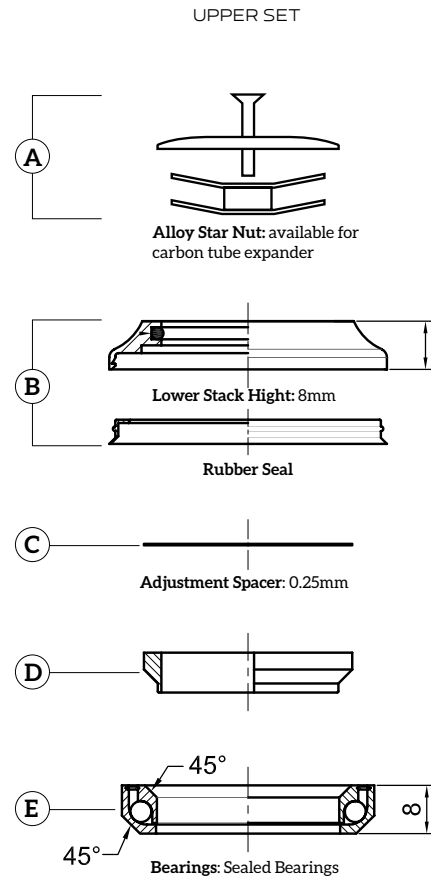

Fork Crown Adaptor

Fork Crown Race Adaptor 1.5" - 1 1/8"



Material: AL7075  
Weight: 12gr.

*The quality of steering headset is assessed by sensitivity and smoothness throughout its lifetime maintenance.*

## COMPONENTS HEADSETS

Prototype headsets have a low profile to keep stack height to a minimum keeping the front end low and fast.

### Semi-integrated

| MSRP: 36 €         | Standard<br>1 1/8" - 1 1/8" | Tapered<br>1 1/8" - 1,5"<br>55mm | Tapered<br>1 1/8" - 1,5"<br>56mm |
|--------------------|-----------------------------|----------------------------------|----------------------------------|
| UPPER BEARING      | 41.8x45°x8                  | 41.8x45°x8                       | 41.8x45°x8                       |
| UPPER CUP          | 44mm                        | 44mm                             | 44mm                             |
| BOTTOM CUP         | 44mm                        | 55mm                             | 56mm                             |
| BOTTOM BEARING     | 41.8x45°x8                  | 51.8x45°x8                       | 51.8x45°x8                       |
| Weight without cap | 76gr                        | 90gr                             | 90gr                             |

### Integrated

| MSRP: 32.50 €      | Standard<br>1 1/8" - 1 1/8" | Standard<br>1 1/8" - 1 1/8" | Tapered<br>1 1/8" - 1 1/4" | Tapered<br>1 1/8" - 1,5" |
|--------------------|-----------------------------|-----------------------------|----------------------------|--------------------------|
| UPPER BEARING      | 41.0x45°x8                  | 41.8x45°x8                  | 41.8x45°x8                 | 41.8x45°x8               |
| BOTTOM BEARING     | 41.0x45°x8                  | 41.8x45°x8                  | 46.8x45°x7                 | 51.8x45°x8               |
| Weight without cap | 70gr                        | 72gr                        | 74gr                       | 76gr                     |

### Spacers

#### Super Light headset spacers

Spacers are super light. Featuring CnC machined inner grooves. Not a single gram is spared.



**Material:** Aluminum  
**Outer ø:** 34mm  
**One Set includes 2pcs:** 5 | 10mm  
**Weight:** 5mm: 1.8gr / 10mm: 3.6gr

MSRP: 4.80 €

### Headset Cap

#### Headset Top Cap



**Material Cap:** AL7075  
**Material Bolt:** M6x35mm AL7075  
**Material Spider:** AL6061 + Steel  
**Weight: Top Cap:** 3.8gr  
**Bolt:** 2.3gr / **Spider:** 5.9gr

MSRP: 6.50 €

Light Force Alloy also provides a high wear resistance even in the worst conditions.

Single Ring

*We developed a single chain ring in order to convert triple or double crank sets into singles with 10 or 11 speeds.*

*Narrow wide tooth profiling ensures ultimate chain retention and alignment. CNC machined from a stiff 4 mm Light Force plane, wich provides a perfect power without flexing.*

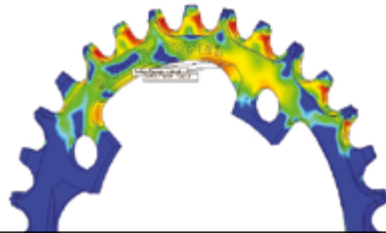

STRESS TEST MATERIAL



**BCD 94 mm**  
Holes: 4  
Teeth: 30, 32, 34

**BCD 104 mm**  
Holes: 4  
Teeth: 30, 32, 34, 36

Weigth 32T: 68.8gr

MSRP: 59.50 €

Jockey Wheels



**Material:** Full CNC machined  
**Teeth:** 11T  
**Weight:** 8.5gr

Available colors



MSRP: 30 € (2ps)

*Performance pulley, with low friction and optimized geometry to improve the operation and precision of the rear derailleurs.*

*Compatible with Shimano, Campagnolo and Sram X-0, XX, Force, Red.*

Cassette Lock Ring



**Fits:** Shimano 11T Cassete Road or MTB  
**Material:** AL7075  
**Weight:** 5,5gr

Available colors



MSRP: 30 € (2ps)



WORKSHOP



# WORKSHOP

## Bearings

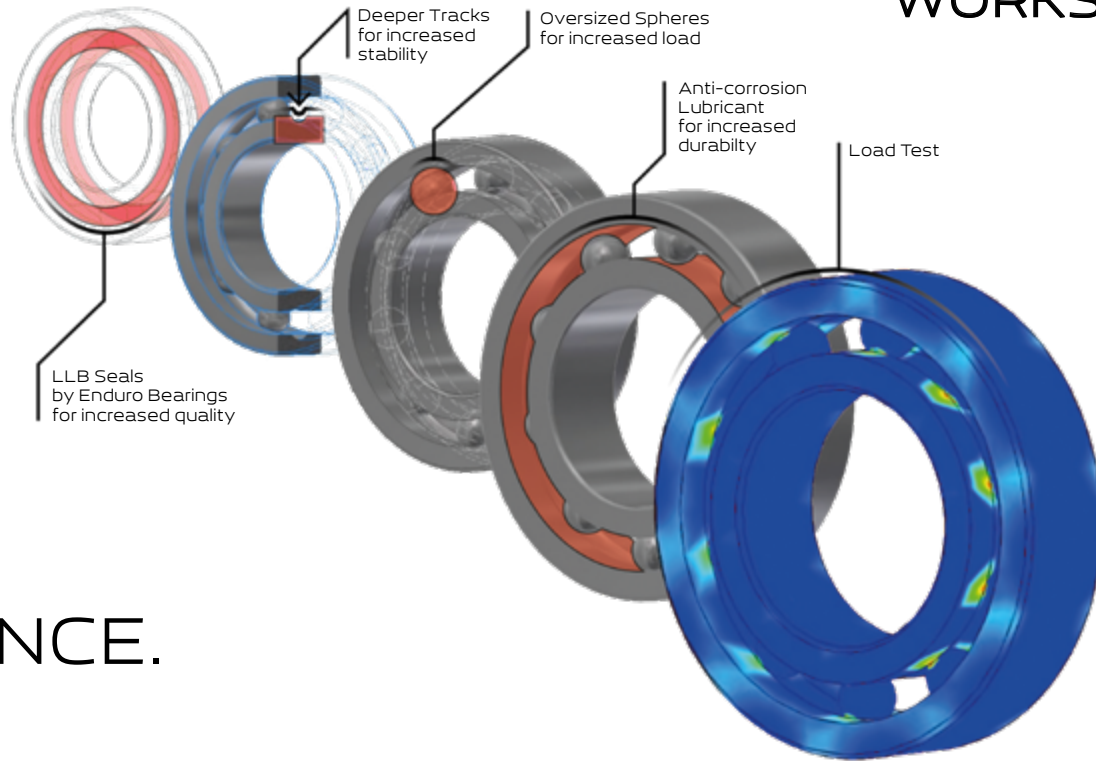

DESIGNED  
AND TESTED  
FOR PERFORMANCE.

### General bearing

| Dimensions    | Designation           |
|---------------|-----------------------|
| 9 x 17 x 5    | 689                   |
| 9 x 24 x 7    | 609                   |
| 10 x 19 x 5   | 6800                  |
| 10 x 22 x 6   | 6900                  |
| 10 x 26 x 8   | 6000                  |
| 12 x 21 x 5   | 6801                  |
| 12 x 24 x 6   | 6901                  |
| 12 x 28 x 8   | 6001                  |
| 15 x 24 x 5   | 6802                  |
| 15 x 26 x 7   | MR15267               |
| 15 x 28 x 7   | 6902                  |
| 16 x 26 x 7   | MR16267               |
| 17 x 26 x 5   | 6803                  |
| 17 x 28 x 7   | MR17287               |
| 17 x 30 x 7   | 6903                  |
| 18 x 30 x 7   | MR18307               |
| 20 x 27 x 7   | 6704                  |
| 20 x 32 x 7   | 6804                  |
| 27.5 x 37 x 7 | MR275377 (Predictive) |

**High precision ball bearings (Abec5) with hardening surface and anti-corrosion treatment.**



### Headset bearing

| Dimensions              | Designation |
|-------------------------|-------------|
| 38.9x6.5x36°            | 1-1/8"      |
| 39x6.5x36°              | 1-1/8"      |
| 41x6.5x45°              | 1-1/8"      |
| 41x7x45°                | 1-1/8"      |
| 41x8x45°                | 1-1/8"      |
| 41.8x6.5x45°            | 1-1/8"      |
| 41.8x8x30.5x45° 1.125T" | 1-1/8"      |
| 41.8x8x45°              | 1-1/8"      |
| 46.8x7x45°              | 1-1/4"      |
| 48.9x6.5x36°/45°        | 1-1.5"      |
| 51.8x8x45°              | 1-1.5"      |
| 52x8x45°                | 1-1.5"      |
| 19/16x21x9°             | Lefty       |
| 19/16x21x9°x45°         | Lefty       |



### Bottom Bracket bearings

| Dimensions       | Designation   |
|------------------|---------------|
| 22 x 37 x 8/11.5 | GXP BSA       |
| 24 x 37 x 7      | MR24377       |
| 25 x 37 x 7      | 6805          |
| 29 x 42 x 7      | 6806/29 (DUB) |
| 30 x 42 x 7      | 6806          |
| 35 x 47 x 7      | 6807          |



# WORKSHOP

## M5 - M6 Bolts



**Material:** Titanium Gr5  
**M5 Dimensions:** 16mm | 20mm | 25mm  
**Weight:** 1,2gr | 1,6gr | 1,7gr  
**M6 Dimensions:** 20mm | 25mm | 35mm | 45mm  
**Weight:** 2gr | 2,2gr | 2,5gr | 3,5gr

Available colors



MSRP: 4.50€ (pc)



**Material:** Aluminum Light Force  
**M5 Dimensions:** 10mm | 16mm | 20mm  
**Weight:** 1gr | 1,3gr | 1,4gr  
**Max Torque:** 5N.m  
**M6 Dimensions:** 15mm | 20mm | 25mm | 35mm  
**Weight:** 1,6gr | 1,8gr | 2,0gr | 2,8gr  
**Max Torque:** 7N.m

Available colors



MSRP: 2.10€ (pc)

## Chainring Bolt



**Material:** Aluminum Light Force  
**Small** 6,5mm  
**Weight:** 5,8gr  
**Large** 8,5mm  
**Weight:** 7gr

Available colors



MSRP: 13.50€ (4pc)

## Bolt SRAM M10



**Material:** Aluminum Light Force  
**Weight:** 4,1gr

Available colors



MSRP: 25€ (4pc)

## Grips



**Material:** 100% Silicone  
**Weight:** 84gr - Comfort / 59gr - Sport

Available colors



MSRP: 18€ (Comf. or Sport)

Visit [www.prototype.pt/support](http://www.prototype.pt/support) to find:

WARRANTY POLICY  
 MANUALS  
 CATALOGS





**PROTOTYPE**<sup>TM</sup> RACING PARTS

WWW.PROTOTYPE.PT

# TRUE HEROES TRUE INSPIRATION

V 2020.2

PROTOTYPE | Leiria-Portugal  
hello@prototype.pt | [www.prototype.pt](http://www.prototype.pt)



**Telmo Pinão**  
Olympic Para-Cycling Athlete